

Installation Guide

Vinyl Rail T-Rail

The following instructions will guide you through the installation of your new vinyl railing.

This installation guide is a recommendation for meeting most code requirements. Always check your local building codes before starting a project and for determining the acceptable installation practices of your area. Please read assembly instructions completely before beginning construction. Always wear protective goggles and gloves when installing a vinyl railing system.

Remember to register your Limited Lifetime Warranty at the web site listed on the product box label.

Tools Required

- Protective eye glasses
- Tape measure
- Variable speed drill/screwdriver
- Rotary hammer or hammer drill and a masonry percussion bit recommended for concrete anchors purchased (for concrete installations)
- Drill bits $\frac{3}{32}$ " , $\frac{1}{4}$ " , $\frac{5}{16}$ " , $\frac{3}{8}$ " , $\frac{1}{2}$ " $\frac{11}{16}$ " , $\frac{1}{8}$ "
- $\frac{3}{8}$ " x 3" Concrete Anchors/Fasteners (for concrete installations)
- Philips Driver and #2 Square Driver
- Wrench and $\frac{3}{4}$ " deep socket
- Level (min 24") and small torpedo level
- Miter Saw
- Snap Line
- Quick Clamp
- (Christy's™) PVC Glue

Installation Steps

Layout railing and position posts

The Vinyl Railing Systems are designed for posts sets of either 72" (6 feet) or 96" (8 feet) between posts. The vinyl rails and aluminum inserts (when required) can be trimmed to shorter lengths using a miter saw. When trimming of the rails is necessary, equal amounts should be cut from both ends of the rails in order to maintain equal spacing from the outer pickets and the adjacent posts.

Determine ahead of time if the post will be anchored to the top of the deck substructure, bolted to the inside of the deck joists, or anchored to concrete. It is best to do a sketch of the general layout in order to plan for post locations and any adjustments to rail lengths. Check measurements for accuracy prior to beginning the project. Determine locations of all line and corner posts. These need to be located inside the joist as shown in the following drawings.

Measure each side of the deck so that line posts are spaced as evenly as possible between the corner posts. Remember that the outside dimensions of the vinyl posts are 4", unlike wood, which could be $3\frac{1}{2}$ " to $3\frac{5}{8}$ ". Also check the structural members below the deck to be sure there is no interference with the mounting brackets. If necessary, adjust the post locations. (Designing your railing so the wood posts are against a floor joist will simplify installations.) After determining the location of the posts, install the corner posts first.

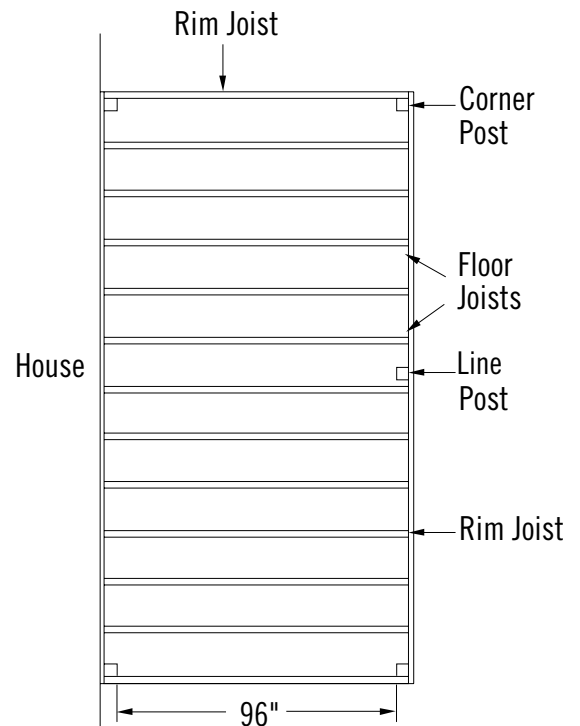

Install posts

Vinyl railing posts can be installed using the following methods:

Post Tower (Concrete and Wooden Decks)

The surface mount tower system is designed for 4" x 4" vinyl posts in railing applications where the posts need to be mounted to a hard surface such as concrete, or this tower system can be used on wood decks when the substructure is modified as detailed at the end of this section. When installed as detailed below, vinyl posts using the post tower can meet post requirements for 42" high rail systems in 1 and 2 family applications.

Install posts – *Continued*

Post Tower on Concrete Decks

- 1) Lay out your post positions according to your railing design. You can use a chalk snap line to mark the railing line and centers of the post locations. Make sure to mark all post positions at least 5" from the edge of the concrete to reduce the chances of cracking the concrete when drilling holes for the concrete anchors.
- 2) Remove the tower assembly and bolt the top adapter plate to the top of the tower in the configuration shown in the assembly drawing.
- 3) Using an adjustable wrench or vice grips, bend the flanges of the top and bottom adapter plates in on all sides so that the post will slide over the tower without damaging the post. Don't bend the tabs in too far as the post should not be able to slide off the tower.
- 4) Place the tower in the designated area on the concrete surface and mark the location of the four bolt holes. Make sure tower is centered over your post location marks.
- 5) Remove the tower. Using a masonry bit, drill four holes deep enough and large enough to accommodate the fasteners that you have chosen. Install concrete anchors.
- 6) Place the tower back into the desired position. Make sure the tower is plumb using a level. If required, shim the tower base with stainless steel washers. Once level, secure to the concrete anchors.
- 7) Slide your posts over the tower and install the railing sections. *(Note: If using a post trim, cut the plastic tabs at the 90 degree bend and slide the trim piece over the post tower. Next slide the post over the tower and into the trim piece.)*

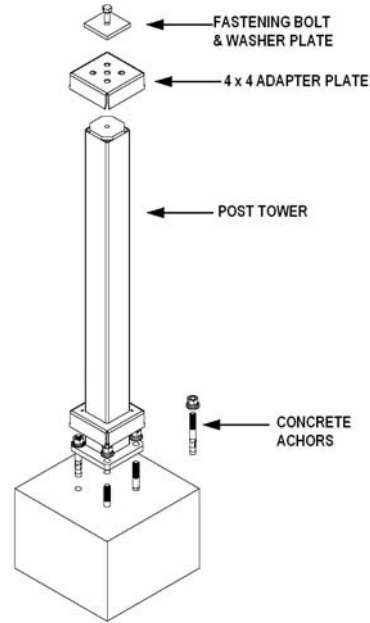

Post Tower on Concrete Decks

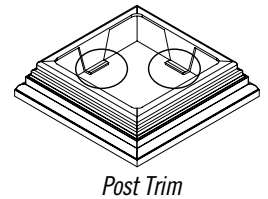

Post Trim

Post Tower on Wooden Decks

- 1) Lay out your post positions according to your railing design. You can use a chalk snap line to mark the railing line and centers of the post locations. Make sure to mark the post center line position at least 3 1/2" from the edge of the rim joist. The top plate must be a minimum of 1" from the rim joist so the bolts will clear the rim joist on the underside of the deck.
- 2) Install a piece of 2" x 8" treated lumber between the joists, under the deck boards where the tower is to be installed. Attach this reinforcement board to the rim joist and stringers. (Three screws should be used on each end.)
- 3) Thickness of the deck board and reinforcement board underneath should be a minimum of 2 1/2" actual thickness.
- 4) Take surface plate and use as a template. Mark the four corner holes for the four 5/16" x 4 1/2" threaded bolts.
- 5) Pre-Drill four 5/16" holes through the marked holes, drilling through the deck board and the reinforcement board.
- 6) Align the surface plate over the holes.
- 7) Take the second plate for underneath and drive the bolts up through the bottom plate, reinforcement board, deck board, surface plate, and tower mount.
- 8) Apply the washers and nuts. Tighten the bolts.
- 9) Bolt the top adapter plate to the top of the tower in the configuration shown in the assembly drawing.
- 10) Using an adjustable wrench or vice grips, bend the flanges of the top and bottom adapter plates in on all sides so that the post will slide over the tower without damaging the post. Don't bend the tabs in too far as the post should not be able to slide off the tower.
- 11) Slide your posts over the tower and install the railing sections.

(Note: If using a post trim, cut the plastic tabs at the 90 degree bend and slide the trim piece over the post tower. Next slide the post over the tower and into the trim piece.)

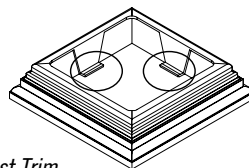

Post Trim

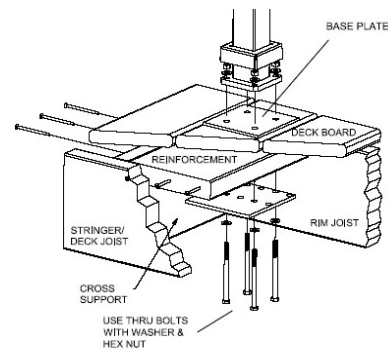

Post Tower on Wooden Decks - For Line Post

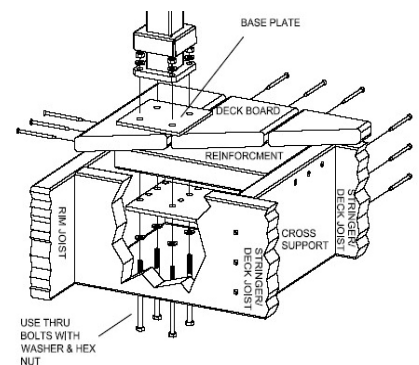

Post Tower on Wooden Decks - For Corner Post

Install posts – Continued

Sleeving a Wood 4" x 4" Post

The vinyl post can be used to sleeve 4" x 4" wooden posts. When installed as detailed below, vinyl posts used as a sleeve can meet post requirements for 42" high rail systems in residential applications. **Note: The instructions reflect how the wood posts were installed during testing to ensure the post attachment and substructure would meet the same load requirements as the railing system. Check with your local code official for other acceptable attachment methods.**

- 1) Designing your deck so the post spacing will end up with a stringer at each post will simplify installation. Lay out your post positions according to your railing design.
- 2) Temporarily attach the wood post in place. For corner post applications and where the post is against a stringer, add an additional stringer on the opposite side of the post. For line post applications, where the post doesn't butt up against a stringer, add a stringer on each side of the post. If the stringers run across the deck, a cross stringer may be placed 24" from the rim joist. The additional stringer(s) attached to the post is then attached to the cross stringer. For all of the applications, add a cross member between the two stringers thus creating a structural box around the post. (Four screws should be used on each end when creating the structural box.)
- 3) Drill two 1/2" holes through the rim joist, wood post, and back cross member 1 1/2" from the top and bottom of the rim joist. Drill one 1/2" hole through the wood post and the stringers on each side. This hole will be perpendicular to the two holes already drilled and should be in the middle of the stringers and post. **For ACQ lumber, all bolts, washers, and nuts must be galvanized.** The bolts through the rim joist have a 1/2" washer, then a 3/4" washer, which is against the wood. Insert bolts and place a 3/4" washer, 1/2" washer and nut on the bolt. The bolt through the stringers and post only has a 1/2" washer on each side. Tighten all bolts.
- 4) Slide your vinyl posts over the wood posts and install the railing sections.
(Note: If using a post trim, cut the plastic tabs at the 90 degree bend. Slide the trim piece over the wood post, then slide the vinyl post over the wood post and into the trim piece.)

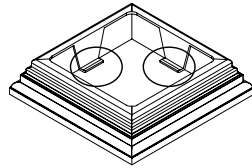

Post Trim

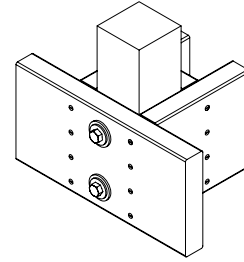

Wood Post Blocking

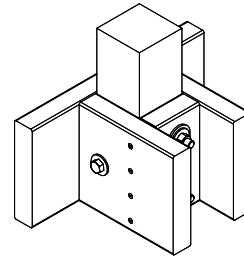

Wood Post Blocking

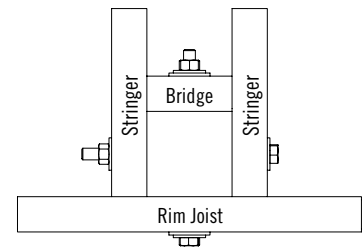

Wood Post Blocking

Vinyl Rail T-Rail Installation

Always check your local building codes before starting a project. Please read assembly instructions completely before beginning construction. Always wear protective goggles and gloves when installing a vinyl railing system.

Vinyl Rail T-Rail Components

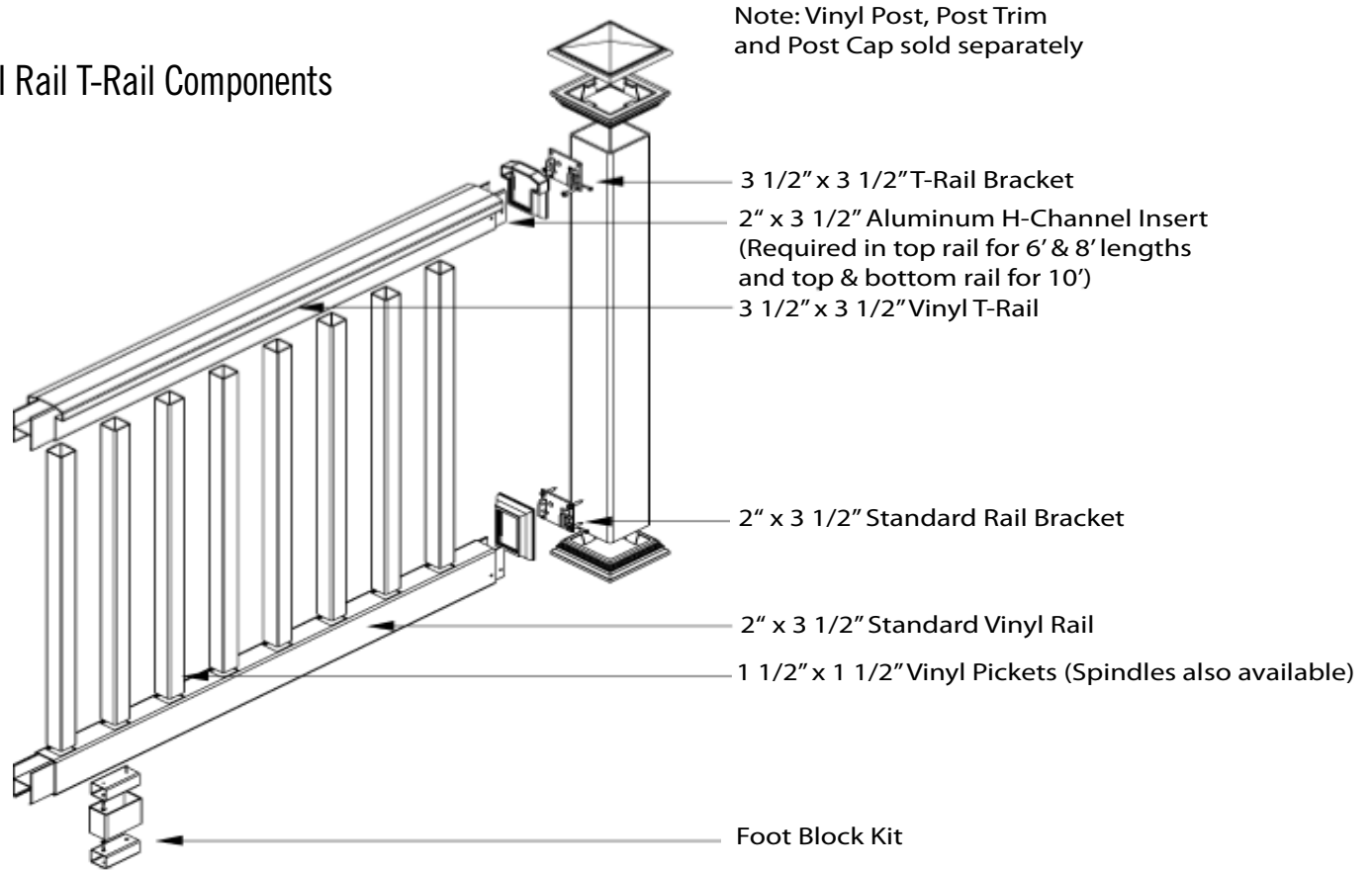

Railing Layout

Remember to check local building codes for rail height requirements in your area. The vinyl railing systems are designed to meet requirements for 36" and 42" high rail systems in residential applications. This is dependent on the post installation methods detailed in the preceding post installation instructions section.

The 2" x 3 1/2" and 3 1/2" x 3 1/2" rails run in between the posts and are installed with brackets. The bottom of the railing section is designed to be 2 1/2" above the surface. Kits are available with 1 1/2" x 1 1/2" pickets or spindles.

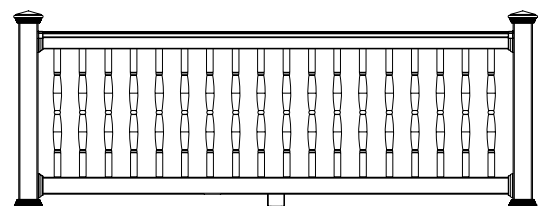
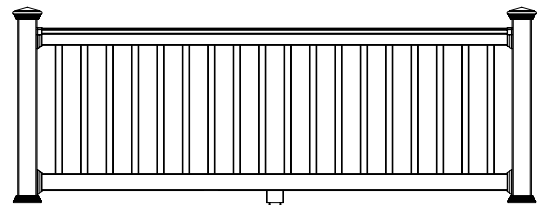

Rail Installation

- 1) **Cut Rails to Length.** Measure distance between posts and subtract $\frac{3}{8}$ " to allow room for the brackets ($\frac{1}{16}$ " each end). Mark the rails to the calculated length using a square. **Important: Make sure that there is equal spacing between the picket hole and end of rail to maintain uniform picket spacing. Do not leave an open picket insert hole at the bracket.** Trim both ends of the rails.
- 2) **Install Post Trim.** Be sure you install the post trim over the posts before you start attaching the stair rail sections to the posts. (Note: You may need to notch the post trim if bottom rail is less than $2\frac{1}{2}$ " from the deck surface.)
- 3) **Install Foot Block and Drill Weep (Drain) Holes.** Center and screw one foot block insert onto the bottom of the bottom rail. Take the $2" \times 3\frac{1}{2}"$ rail and drill three $\frac{1}{4}"$ drain holes on the underside of the bottom rail. The other foot block insert is aligned and attached in between the posts on the corresponding walking surface. **Foot block kits are required on all railing sections 6' or longer.**
- 4) **Install Bottom Rail.** (Note: 6' and 8' horizontal kits do not require aluminum inserts in the bottom rails, only in the top rails. 10' kits require aluminum inserts in both top and bottom rails.) Slide the aluminum insert into the $2" \times 3\frac{1}{2}"$ rail such that the shorter legs of the "H" are up towards the side with the picket holes. Trim the insert to match the length of the rail. Slide trim pieces onto the bottom rail facing the finished trim towards the center of the rail. After making certain that the aluminum insert is positioned with the shorter legs facing the hole, slide the $2" \times 3\frac{1}{2}"$ brackets at both ends the bottom rail. Lower bottom rail (the rail with your drain holes) into position between posts and set onto the foot block. Make sure the holes for the pickets are facing up. Ensure the rail is level and the brackets are centered on the post. Pre-drill the post through the four outside holes with a $\frac{1}{8}"$ drill bit and attach bracket to the post using four of the $\#12 \times 1\frac{1}{4}"$ screws provided. Drive two (one on each side) $\#8 \times \frac{3}{4}"$ screws provided, through the bottom side hole (Pre-drill with a $\frac{3}{32}"$ drill). These side screws go through the vinyl and insert. This will provide the mechanical attachment of the rail to the bracket. Snap trim in place. Repeat for the other bracket.
- 5) **Install Top Brackets.** Insert one picket or spindle in the far left hole and another picket or spindle in the far right hole. Insert the aluminum insert into the T-Rail such that the shorter legs of the insert are facing the hole. Feed the top T-Rail onto the pickets or spindles. Slide a T-Rail bracket under the end of each rail such that the bracket is butted up to the "T" portion of the rail. Make sure the rail is centered on the post and level and then mark the post under the brackets. Remove the top rail and set aside. Line the bottom of the black bracket with the line that you just marked. Center the bracket on the post and pre-drill the post through the bottom two outside holes and the inner two holes in the center with $\frac{1}{8}"$ bit. Secure the bracket in place using two $\#12 \times 1\frac{1}{4}"$ screws provided in the bottom two holes and the $\#12 \times 1"$ countersunk screws provided in the center holes. Repeat with the other top bracket.
- 6) **Install Top Rail.** Slide the aluminum insert into the $3\frac{1}{2}" \times 3\frac{1}{2}"$ T-rail such that the shorter legs of the "H" are down towards the side with the picket holes. Trim the insert to match the length of the rail. Slide trim pieces onto the top rail facing the finished trim towards the center of the rail. Insert the remaining pickets or spindles in to the bottom rail. Starting at one end of the rail begin feeding the rail down onto the pickets or spindles. Once the top of the rail has been seated onto all the pickets and the rail is level, drive two (one on each side) $\#8 \times \frac{3}{4}"$ screws provided, through the bottom side hole (Pre-drill with a $\frac{3}{32}"$ drill). These side screws go through the vinyl and insert. This will provide the mechanical attachment of the rail to the bracket. Snap trim in place. Repeat for the other bracket.
- 7) **Install Post Cap.** Place a $1" \times \frac{1}{4}"$ wide bead of glue on inside of cap along the center of all four sides. Slide cap onto top of post. The glue will smear as the cap is slid on the post and a permanent bond will take effect after a few minutes. Be careful not to drip glue on the outside of a post or cap or it will cause a "scar".

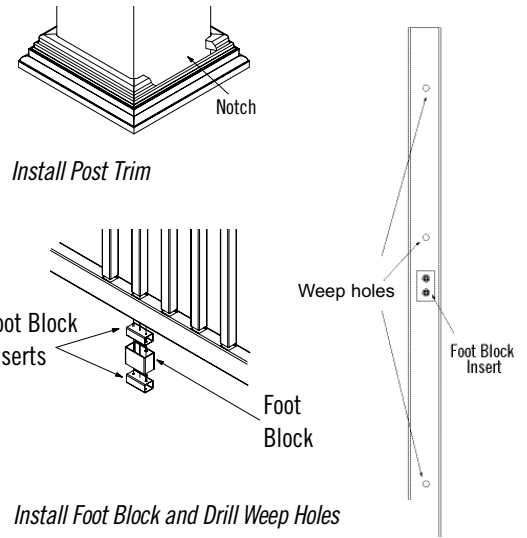

Install Foot Block and Drill Weep Holes

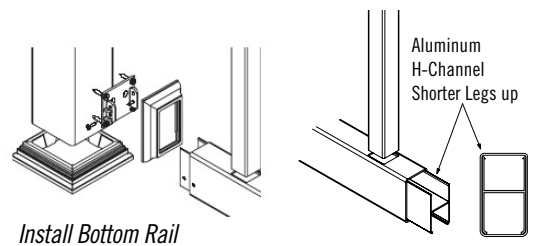

Install Bottom Rail

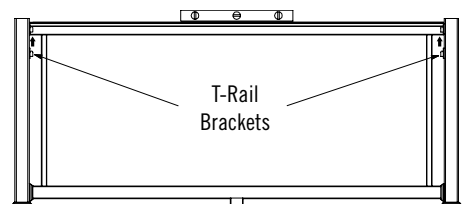
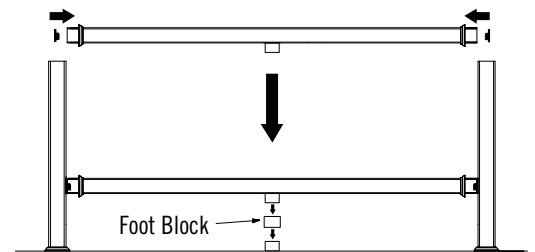

Install Pickets and Top Rail

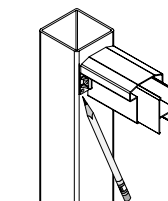

Install Top Rail

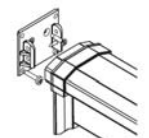

T-Rail Bracket

Cleaning

If cleaning becomes necessary, use a mild detergent or household cleaner. If stains or scuff marks appear, use a fiberglass cleaner/glaze or #0000 steel wool and Simple Green™.

Important

It is the responsibility of the contractor to meet or exceed all code and safety requirements, and to obtain all required building permits. These instructions are only a guide, and may not address every circumstance. The deck and railing installer should determine and implement appropriate installation techniques for each situation. Manufacturer shall not be held liable for improper or unsafe installations.